

**1 TYPE (BASE PLATE)**

- Type **C3** polished, rubber vulcanized, black.



Versions of threaded studs:

- Type **SK**: external hex at the bottom.

- Type **TK**: wrench flat at the bottom.



Base

AISI 316L stainless steel



Threaded stem

AISI 316L stainless steel



Hex nut ISO 4032

AISI 316 stainless steel



Rubber pad

Acrylonitrile butadiene rubber (NBR)

- Black

- FDA-compliant

- Hardness 85±5 Shore A

- Vulcanized

**8 FEATURES AND APPLICATIONS**

Levelling feet GN 18 are particularly suitable for use in aggressive environments.

The inclined surfaces for liquid runoff and the high surface quality of the base plate simplify cleaning and prevent the accumulation of dust or dirt. The FDA compliant and vulcanized rubber underlay seals the base against the resting surface and allows the feet to be used in food-processing areas or the pharmaceutical industry, for example.

The levelling feet are supplied assembled and cannot be disassembled.

**ON REQUEST**

Rubber pad available in various colours

**LOAD CAPACITY OF THE ADJUSTABLE FEET**

The static load values indicated in the table refer to laboratory tests with application of the load perpendicular to the base (without rubber disc).

For the values shown in the table, the removal of the load can cause slight deformations of the base plate. Under common working conditions, side or angular loading increases the stress on the levelling element and reduces its carrying capacity.

The details given on strength are non binding guide values without any liability.

It's the user's responsibility to determine, case by case, whether the product is suitable for the intended use.

Environmental factors may influence the declared values.



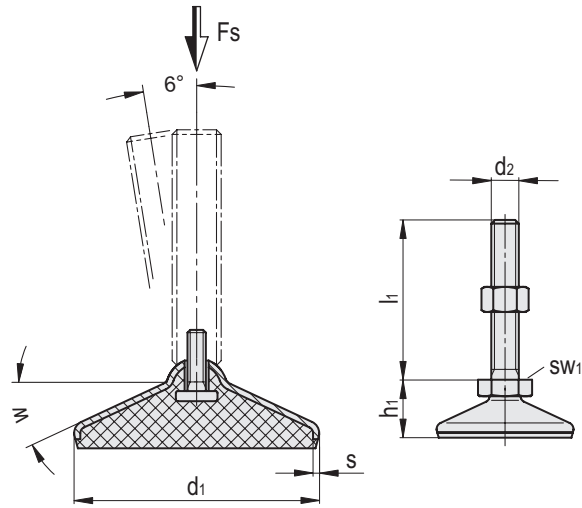

GN 18-SK

INOX STAINLESS STEEL

Code	Description	d1	d2	h1	l1	s	sw1	w [mm]	Static load [kN]	⚖
GN.20901	GN 18-60-M8-40-C3-SK	60	M 8	31	40	2	17	32	8	125
GN.20902	GN 18-60-M8-50-C3-SK	60	M 8	31	50	2	17	32	8	128
GN.20903	GN 18-60-M8-63-C3-SK	60	M 8	31	63	2	17	32	8	132
GN.20904	GN 18-60-M10-50-C3-SK	60	M 10	31	50	2	17	32	14	143
GN.20905	GN 18-60-M10-60-C3-SK	60	M 10	31	60	2	17	32	14	147
GN.20906	GN 18-60-M10-80-C3-SK	60	M 10	31	80	2	17	32	14	157
GN.20907	GN 18-60-M10-100-C3-SK	60	M 10	31	100	2	17	32	14	167
GN.20908	GN 18-60-M12-60-C3-SK	60	M 12	31	60	2	17	32	14	160
GN.20909	GN 18-60-M12-80-C3-SK	60	M 12	31	80	2	17	32	14	175
GN.20910	GN 18-60-M12-100-C3-SK	60	M 12	31	100	2	17	32	14	189
GN.20911	GN 18-60-M12-125-C3-SK	60	M 12	31	125	2	17	32	14	207
GN.20912	GN 18-80-M8-40-C3-SK	80	M 8	33	40	2	17	26	8	197
GN.20913	GN 18-80-M8-50-C3-SK	80	M 8	33	50	2	17	26	8	200
GN.20914	GN 18-80-M8-63-C3-SK	80	M 8	33	63	2	17	26	8	204
GN.20915	GN 18-80-M10-50-C3-SK	80	M 10	33	50	2	17	26	14	216
GN.20916	GN 18-80-M10-60-C3-SK	80	M 10	33	60	2	17	26	14	220
GN.20917	GN 18-80-M10-80-C3-SK	80	M 10	33	80	2	17	26	14	230
GN.20918	GN 18-80-M10-100-C3-SK	80	M 10	33	100	2	17	26	14	240
GN.20919	GN 18-80-M12-60-C3-SK	80	M 12	33	60	2	17	26	14	233
GN.20920	GN 18-80-M12-80-C3-SK	80	M 12	33	80	2	17	26	14	248
GN.20921	GN 18-80-M12-100-C3-SK	80	M 12	33	100	2	17	26	14	262
GN.20922	GN 18-80-M12-125-C3-SK	80	M 12	33	125	2	17	26	14	280
GN.20923	GN 18-100-M8-40-C3-SK	100	M 8	35	40	2	17	22	8	292
GN.20924	GN 18-100-M8-50-C3-SK	100	M 8	35	50	2	17	22	8	295
GN.20925	GN 18-100-M8-63-C3-SK	100	M 8	35	63	2	17	22	8	299
GN.20926	GN 18-100-M10-50-C3-SK	100	M 10	35	50	2	17	22	14	311
GN.20927	GN 18-100-M10-60-C3-SK	100	M 10	35	60	2	17	22	14	315
GN.20928	GN 18-100-M10-80-C3-SK	100	M 10	35	80	2	17	22	14	325
GN.20929	GN 18-100-M10-100-C3-SK	100	M 10	35	100	2	17	22	14	335
GN.20930	GN 18-100-M12-60-C3-SK	100	M 12	35	60	2	17	22	14	328
GN.20931	GN 18-100-M12-80-C3-SK	100	M 12	35	80	2	17	22	14	343
GN.20932	GN 18-100-M12-100-C3-SK	100	M 12	35	100	2	17	22	14	357
GN.20933	GN 18-100-M12-125-C3-SK	100	M 12	35	125	2	17	22	14	375

- 1
- 2
- 3
- 4
- 5
- 6
- 7
- 8
- 9
- 10
- 11
- 12
- 13
- 14
- 15
- 16
- 17
- 18

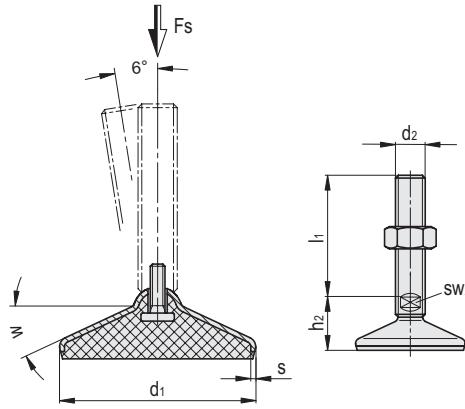

INOX STAINLESS STEEL

GN 18-TK

Code	Description	d1	d2	h2	l1	s	sw2	w [°]	Static load [kN]	
GN.20941	GN 18-60-M16-75-C3-TK	60	M 16	37	75	2	12	32	14	239
GN.20942	GN 18-60-M16-100-C3-TK	60	M 16	37	100	2	12	32	14	272
GN.20943	GN 18-60-M16-125-C3-TK	60	M 16	37	125	2	12	32	14	305
GN.20944	GN 18-60-M16-150-C3-TK	60	M 16	37	150	2	12	32	14	341
GN.20945	GN 18-60-M16-200-C3-TK	60	M 16	37	200	2	12	32	14	404
GN.20946	GN 18-60-M16-250-C3-TK	60	M 16	37	250	2	12	32	14	470
GN.20947	GN 18-80-M16-75-C3-TK	80	M 16	39	75	2	12	26	14	312
GN.20948	GN 18-80-M16-100-C3-TK	80	M 16	39	100	2	12	26	14	345
GN.20949	GN 18-80-M16-125-C3-TK	80	M 16	39	125	2	12	26	14	378
GN.20950	GN 18-80-M16-150-C3-TK	80	M 16	39	150	2	12	26	14	414
GN.20951	GN 18-80-M16-200-C3-TK	80	M 16	39	200	2	12	26	14	477
GN.20952	GN 18-80-M16-250-C3-TK	80	M 16	39	250	2	12	26	14	543
GN.20953	GN 18-80-M20-75-C3-TK	80	M 20	39	75	2	15	26	32	358
GN.20954	GN 18-80-M20-100-C3-TK	80	M 20	39	100	2	15	26	32	410
GN.20955	GN 18-80-M20-125-C3-TK	80	M 20	39	125	2	15	26	32	461
GN.20956	GN 18-80-M20-150-C3-TK	80	M 20	39	150	2	15	26	32	516
GN.20957	GN 18-80-M20-200-C3-TK	80	M 20	39	200	2	15	26	32	616
GN.20958	GN 18-80-M20-250-C3-TK	80	M 20	39	250	2	15	26	32	719
GN.20959	GN 18-80-M24-100-C3-TK	80	M 24	41	100	2	19	26	36	519
GN.20960	GN 18-80-M24-125-C3-TK	80	M 24	41	125	2	19	26	36	594
GN.20961	GN 18-80-M24-150-C3-TK	80	M 24	41	150	2	19	26	36	669
GN.20962	GN 18-80-M24-200-C3-TK	80	M 24	41	200	2	19	26	36	818
GN.20963	GN 18-80-M24-300-C3-TK	80	M 24	41	300	2	19	26	36	1119
GN.20964	GN 18-100-M16-75-C3-TK	100	M 16	41	75	2	12	22	24	407
GN.20965	GN 18-100-M16-100-C3-TK	100	M 16	41	100	2	12	22	24	440
GN.20966	GN 18-100-M16-125-C3-TK	100	M 16	41	125	2	12	22	24	473
GN.20967	GN 18-100-M16-150-C3-TK	100	M 16	41	150	2	12	22	24	509
GN.20968	GN 18-100-M16-200-C3-TK	100	M 16	41	200	2	12	22	24	572
GN.20969	GN 18-100-M16-250-C3-TK	100	M 16	41	250	2	12	22	24	638
GN.20970	GN 18-100-M20-75-C3-TK	100	M 20	41	75	2	15	22	26	453
GN.20971	GN 18-100-M20-100-C3-TK	100	M 20	41	100	2	15	22	26	505
GN.20972	GN 18-100-M20-125-C3-TK	100	M 20	41	125	2	15	22	26	556
GN.20973	GN 18-100-M20-150-C3-TK	100	M 20	41	150	2	15	22	26	611
GN.20974	GN 18-100-M20-200-C3-TK	100	M 20	41	200	2	15	22	26	711
GN.20975	GN 18-100-M20-250-C3-TK	100	M 20	41	250	2	15	22	26	814
GN.20976	GN 18-100-M24-100-C3-TK	100	M 24	43	100	2	19	22	28	614
GN.20977	GN 18-100-M24-125-C3-TK	100	M 24	43	125	2	19	22	28	689
GN.20978	GN 18-100-M24-150-C3-TK	100	M 24	43	150	2	19	22	28	764
GN.20979	GN 18-100-M24-200-C3-TK	100	M 24	43	200	2	19	22	28	913
GN.20980	GN 18-100-M24-300-C3-TK	100	M 24	43	300	2	19	22	28	1214
GN.20981	GN 18-120-M20-75-C3-TK	120	M 20	43	75	2	15	20	26	574
GN.20982	GN 18-120-M20-100-C3-TK	120	M 20	43	100	2	15	20	26	626
GN.20983	GN 18-120-M20-125-C3-TK	120	M 20	43	125	2	15	20	26	677
GN.20984	GN 18-120-M20-150-C3-TK	120	M 20	43	150	2	15	20	26	732
GN.20985	GN 18-120-M20-200-C3-TK	120	M 20	43	200	2	15	20	26	832
GN.20986	GN 18-120-M20-250-C3-TK	120	M 20	43	250	2	15	20	26	935
GN.20987	GN 18-120-M24-100-C3-TK	120	M 24	46	100	2	19	20	26	735
GN.20988	GN 18-120-M24-125-C3-TK	120	M 24	46	125	2	19	20	26	810
GN.20989	GN 18-120-M24-150-C3-TK	120	M 24	46	150	2	19	20	26	885
GN.20990	GN 18-120-M24-200-C3-TK	120	M 24	46	200	2	19	20	26	1034
GN.20991	GN 18-120-M24-300-C3-TK	120	M 24	46	300	2	19	20	26	1335

Levelling feet and supports